

ViaLiteHD® – Yellow OEM Link

RF over Fiber OEM Module

- Single Tx or Rx
- 50 and 75 ohm versions
- Board-mounted OEM
- Edge connector
- 65 x 40 x 15.6 mm*
- All **ViaLiteHD** RF bands available up to 4.2 GHz
- Support modules also available

*Wideband OEM is double cased; depth increases

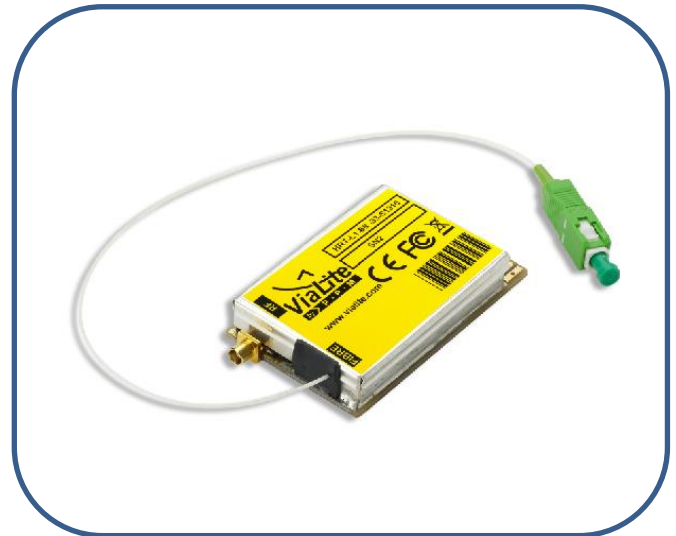

The Yellow OEM Link is a small board-mounted RF over fiber OEM module, available in all **ViaLiteHD** RF bands up to 4.2 GHz and can be supplied in transmitter or receiver formats. It can be used within the **ViaLiteHD** ODE-A4 and ODE-MINI outdoor enclosures or easily mounted into customer equipment. The unit is available with either an SC/APC, LC/APC, FC/APC or E2000/APC optical connector, and either SMA or MCX RF connector (note: optical and RF connector option availability will be dependent on module type).

The OEM module comes with a 15 pin edge connector which allows connections for powering, Tx or Rx alarms, I2C setup for monitoring and control, and serial data transmission such as RS232, RS485 & TTL. By using the **ViaLiteHD** Programming Kit (HRx-HD-DEV103), the module gain settings can be changed accordingly.

Mechanical Dimensions (mm)

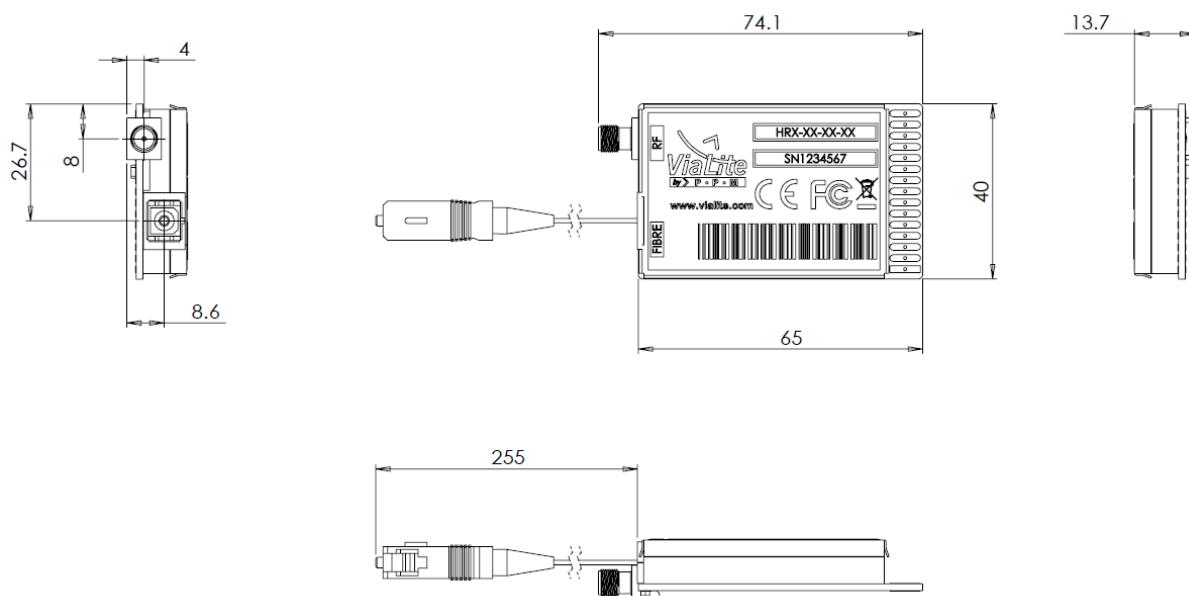

Technical specification

	Yellow OEM Link
Dimensions	Transmitter: 65 x 40 x 15.6 mm Receiver: 65 x 40 x 12.1 mm <i>*Wideband OEM is double canned; depth increases</i>
Weight	Transmitter: 60 g Receiver: 55 g
Operating temperature	-10 °C to +60 °C
Humidity	0-95% non-condensing
Cooling	Convection
Power consumption	Transmitter: 1.9 W Receiver: 1.3 W
DC Input voltage	11 to 13 V, 12 V nominal
Connector	15-pin edge connector (Power, Serial Data, Alarms & I2C programming)
RF module Types	Transmitter or Receiver IF (B), DVB-T (D), GPS (G), L-Band HTS (L), General purpose (N), Wideband (S), Low Frequency Timing Link (T), Ultra Wideband (U&W), 1:1 Splitter, 1:1 Switch, Serial digital and Ethernet.