

FREQUENCY CONVERTER

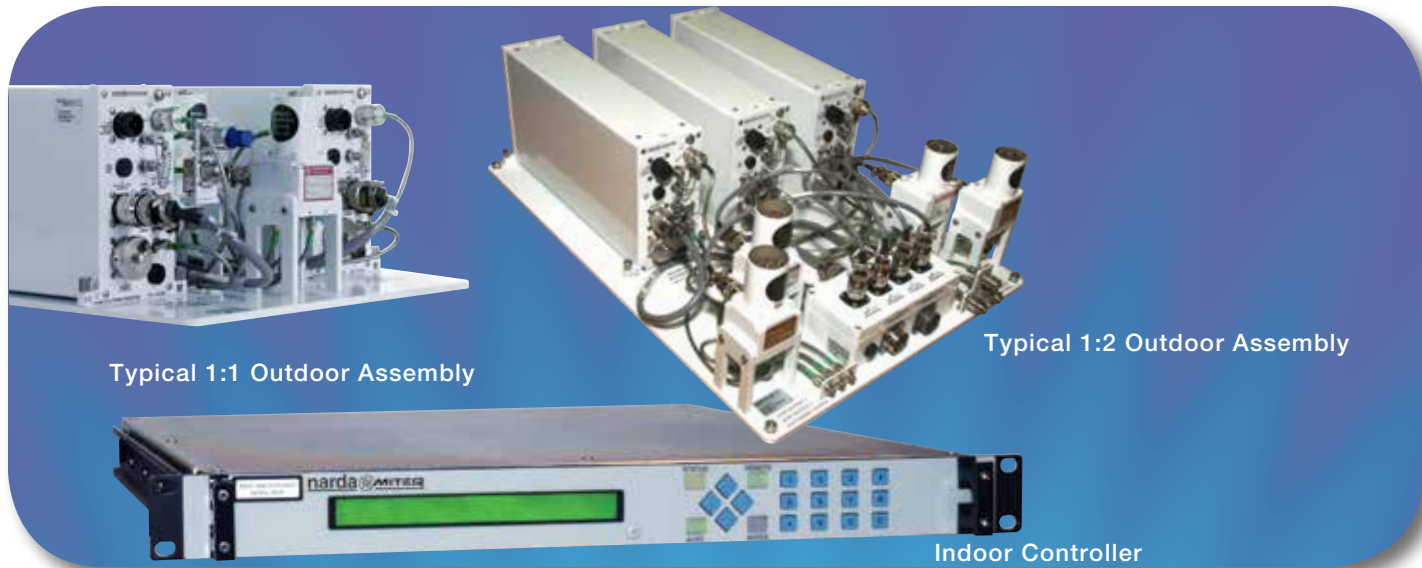

1:1 AND 1:2 REDUNDANT BLOCKCONVERTER SYSTEM



FEATURES

- Automated backup and monitoring of block converters
- Coverage for all SATCOM bands
- Antenna mount, weatherproof
- Fault-tolerant design
- Redundant hot-swappable power supplies on controller
- Remote control and status via 10/100 Base-T Ethernet and RS-485/RS-422
- Automatic/manual control
- Time-stamped event history
- Continuous operation during fault repair or maintenance
- AC power supply (CE mark)

OPTIONS

- Input/output signal monitors
- Longer length interface cables

Completely integrated 1:1 or 1:2 redundant block converter assemblies provide continuous RF operation without loss of signal on a completely automated basis.

The redundant assembly is a weather resistant, antenna mount, single-plate assembly, completely integrated with controller interface, switching elements and block converters. The redundant assemblies are available to cover all SATCOM receive and transmit bands: C, X, Ku, DBS, K and Ka - commercial and military bands using the WS series of high-performance block converters (see datasheet D-327 for the block converter specifications).

The control and monitoring of the converters is provided by a rack mounted local control switchover unit. The controller is based on the NSU series (see datasheet D-323) and is included with the redundant converter plate assembly. Interface cables connecting the rack-mounted controller to the antenna-mounted plate assembly are also included. The 1:1 system uses a single cable, while the 1:2 system uses two. Standard cable length is 100 feet [30.5 m], with longer cable lengths available in 10 foot [3 m] increments as an option. Maximum cable length for a 1:1 system is 250 feet [76.2 m]. Maximum cable length for a 1:2 system is 328 feet [100 m].



FREQUENCY CONVERTER

AVAILABLE BLOCK UP AND DOWNCONVERTERS FOR REDUNDANT SYSTEMS

BLOCK UP CONVERTERS

RF FREQUENCY (GHz)	IF FREQUENCY (GHz)	LO FREQUENCY (GHz)	MODEL NUMBER
5.85 to 6.425	950 to 1525	7.375	UPB-WS-6.1-IN*
5.85 to 6.65	950 to 1750	4.9	UPB-WS-6.25
6.7 to 7.1	950 to 1350	5.75	UPB-WS-6.9
7.9 to 8.4	950 to 1450	6.95	UPB-WS-8.15
11.7 to 12.75	950 to 2000	10.75	UPB-WS-12.225**
12.75 to 13.25	950 to 1450	11.8	UPB-WS-13
13.75 to 14.5	950 to 1700	12.8	UPB-WS-14.125
14 to 14.5	950 to 1450	13.05	UPB-WS-14.25
17.3 to 18.4	950 to 2050	16.35	UPB-WS-17.85**
18.1 to 18.4	950 to 1250	17.15	UPB-WS-18.25

Ka-BAND

RF FREQUENCY (GHz)	IF FREQUENCY (GHz)	LO FREQUENCY (GHz)	MODEL NUMBER
19.2 to 20.2	950 to 1950	18.25	UPB-WS-19.7**
20.2 to 21.2	1000 to 2000	19.2	UPB-WS-20.7-1**
25.5 to 27.0	950 to 2450	24.55	UPB-WS-26.25-1.5**
27.5 to 28.0	950 to 1450	26.55	UPB-WS-27.75
28.0 to 28.5	950 to 1450	27.05	UPB-WS-28.25
28.1 to 28.6	950 to 1450	27.15	UPB-WS-28.35
28.35 to 28.6	950 to 1200	27.4	UPB-WS-28.475
28.5 to 29.0	950 to 1450	27.55	UPB-WS-28.75
28.6 to 29.1	950 to 1450	27.65	UPB-WS-28.85
28.75 to 29.35	950 to 1550	27.8	UPB-WS-29.05
28.8 to 30.0	950 to 2150	27.85	UPB-WS-29.4**
29.0 to 29.5	950 to 1450	28.05	UPB-WS-29.25
29 to 30	1000 to 2000	28.00	UPB-WS-29.5-1**
29.5 to 30.0	950 to 1450	29.55	UPB-WS-29.75
30 to 31	950 to 1950	29.05	UPB-WS-30.5**
30 to 31	1000 to 2000	29.00	UPB-WS-30.5-1**

BLOCK DOWN CONVERTERS

RF FREQUENCY (GHz)	IF FREQUENCY (GHz)	LO FREQUENCY (GHz)	MODEL NUMBER
3.4 to 4.2	950 to 1750	5.15	DNB-WS-3.8-IN*
3.4 to 4.2	950 to 1750	8.85/11.3	DNB-WS-3.8B
3.7 to 4.2	950 to 1450	8.85/11.3	DNB-WS-3.95
7.25 to 7.75	950 to 1450	6.3	DNB-WS-7.5
10.7 to 11.7	950 to 1950	9.75	DNB-WS-11.2**
10.95 to 11.7	950 to 1700	10	DNB-WS-11.325
11.2 to 12	950 to 1750	10.25	DNB-WS-11.6
11.45 to 12.25	950 to 1750	10.5	DNB-WS-11.85
11.7 to 12.5	950 to 1750	10.75	DNB-WS-12.1
11.7 to 12.75	950 to 2000	10.75	DNB-WS-12.225**
12.2 to 12.75	950 to 1500	11.25	DNB-WS-12.475
12.25 to 12.75	950 to 1450	11.3	DNB-WS-12.5

Note: All converters must have the Vertical Mount (VM) option configuration.

* Model includes frequency inversion.

** Wideband IF models; 1 GHz to 1.5 GHz standard and broader bandwidths available.



AVAILABLE BLOCK UP AND DOWNCONVERTERS FOR REDUNDANT SYSTEMS

Ka-BAND

RF FREQUENCY (GHz)	IF FREQUENCY (GHz)	LO FREQUENCY (GHz)	MODEL NUMBER
18.3 to 18.8	950 to 1450	17.35	DNB-WS-18.55
18.8 to 19.3	950 to 1450	18.85	DNB-WS-19.05
19.7 to 20.2	950 to 1450	18.75	DNB-WS-19.95
20.2 to 21.2	950 to 1950	19.25	DNB-WS-20.7**
20.2 to 21.2	1000 to 2000	19.2	DNB-WS-20.7-1**
25.5 to 27.0	950 to 2450	24.55	DNB-WS-26.25-1.5**
27.5 to 28.0	950 to 1450	26.55	DNB-WS-27.75
27.6 to 29.1	950 to 2450	26.65	DNB-WS-28.35-1.5**
28.0 to 28.5	950 to 1450	27.05	DNB-WS-28.25
28.1 to 28.6	950 to 1450	27.15	DNB-WS-28.35
28.35 to 28.6	950 to 1200	27.4	DNB-WS-28.475
28.5 to 29.0	950 to 1450	27.55	DNB-WS-28.75
28.6 to 29.0	950 to 1450	27.65	DNB-WS-28.85
28.8 to 30.0	950 to 2150	27.85	DNB-WS-29.4**
29.0 to 29.5	950 to 1450	28.05	DNB-WS-29.25
29 to 30	1000 to 2000	28	DNB-WS-29.5-1**
29.5 to 30.0	950 to 1450	29.55	DNB-WS-29.75
30 to 31	950 to 1950	29.05	DNB-WS-30.5**
30 to 31	1000 to 2000	29	DNB-WS-30.5-1**

Note: All converters must have the Vertical Mount (VM) option configuration.

* Model includes frequency inversion.

** Wideband IF models; 1 GHz to 1.5 GHz standard and broader bandwidths available.

MODEL NUMBER CONFIGURATION

MODEL NUMBER: RB _____ -WS- _____ Examples:

U - Block Upconverter
 D - Block Downconverter
 1 - 1:1 Redundant System
 2 - 1:2 Redundant System
 Center Frequency of Converters
 (Based on D-327 model numbers)

- 1) RBU1-WS-14.125 is a 1:1 Redundant Block Upconverter System using two BUCs M/N UPB-WS-14.125 (with VM, Vertical Mount Option).
- 2) RBD2-WS-7.5 is a 1:2 Redundant Block Downconverter System using three BDCs M/N DNB-WS-7.5 (with VM, Vertical Mount Option).

OPTIONS

Missing option numbers are not applicable for this product.

6-[x]. Local control unit to converter/plate assembly cable length, where [x] is the length of the cable in 10 foot increments. 1:1 system maximum length is 250 feet [76.2 m], 1:2 system maximum length is 328 feet [100 m].

FREQUENCY CONVERTER

1:1 REDUNDANT BUC SYSTEM BLOCK DIAGRAM

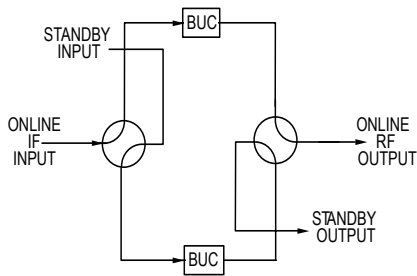

1:1 REDUNDANT BDC SYSTEM BLOCK DIAGRAM

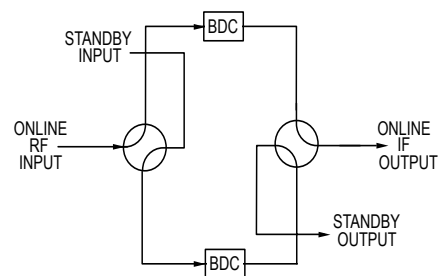

1:2 REDUNDANT BDC SYSTEM BLOCK DIAGRAM

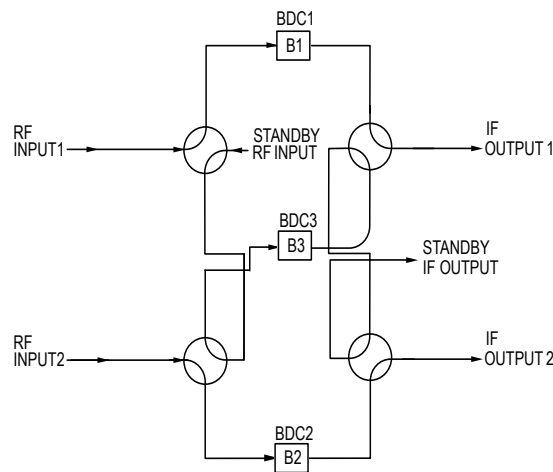

1:1 Ka-BAND BDC OUTLINE DRAWING

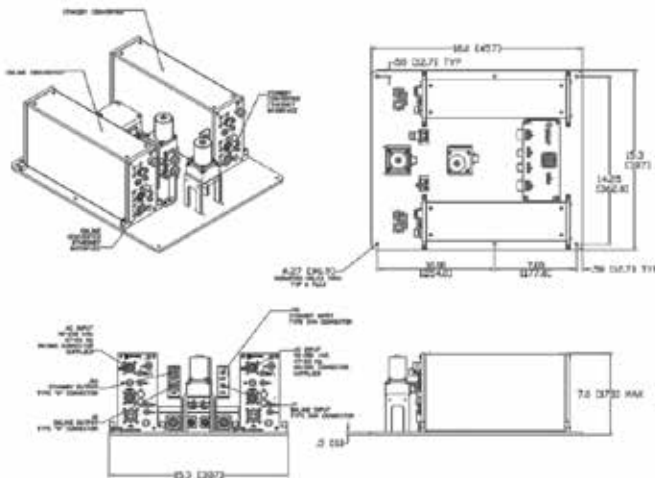

1:1 Ka-BAND BUC OUTLINE DRAWING

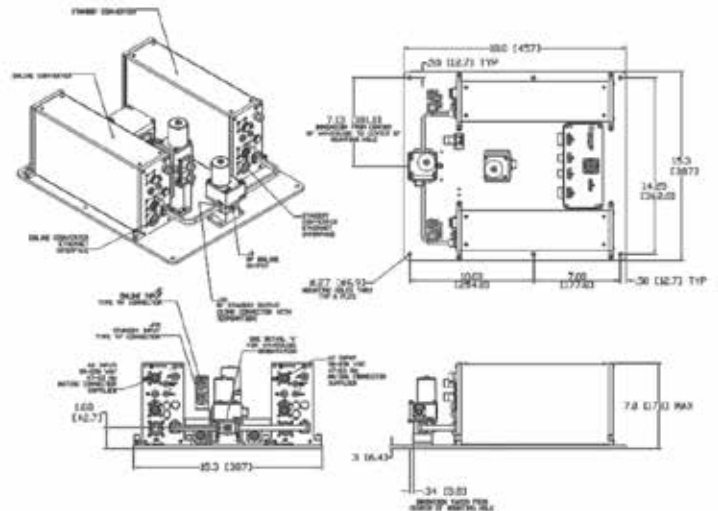

Note: Dimensions shown are in inches and those shown in brackets [] are in millimeters.



GENERAL SPECIFICATIONS

PRIMARY POWER REQUIREMENTS

Voltage.....100 VAC to 240 VAC (-10%, +6%)

Frequency47 Hz to 63 Hz

Power consumption50 W typical

Note: Converters AC power.....25 W typical each

SUMMARY ALARM

Contact closure/open for DC voltage and/or amplifier alarm

Status alarm readout on remote control bus

PHYSICAL

Controller

AC input connectorIEC-320

Summary alarm interfaceDEM-9P

Remote interface.....DEM-9S for RS-422/RS-485, RJ-45 female for Ethernet

1:1 plate interface.....DB-25S to plate interface box

1:2 plate interfacesDB-25S to converter interface, DB-37P to switch control interface

Weight20 lb. [9.07 kg] typical

Overall dimensions.....19.0" [482.6 mm] x 1.75" [44.5 mm] panel x 20.0" [508 mm]
(excluding connectors)

Outdoor Assembly

RF connectorsSMA female up to 21.2 GHz, WR-28 for Ka-Band upconverters

IF connectors.....Type N female

Remote interfaceRJ-45 female for Ethernet (on converters)

Weight

1:1 plate.....30 lb. [13.60 kg] typical

1:2 plate.....45 lb. [20.41 kg] typical

Overall dimensions

1:1 plate.....15.3" [388.6 mm] x 18.0" [457.2 mm] x 8.0" [203.2 mm] height

1:2 plate (except Ka-Band BUC)18.3" [464.8 mm] x 24.0" [609.6 mm] x 8.0" [203.2 mm] height

1:2 plate (Ka-Band BUC).....19.875" [504.8 mm] x 30.0" [762 mm] x 8.0" [203.2 mm] height

FREQUENCY CONVERTER

GENERAL SPECIFICATIONS (CONTINUED)

ENVIRONMENTAL

Operating

- Ambient temperature (controller) 0 °C to 50 °C
- Ambient temperature (outdoor assembly) -40 °C to +60 °C
- Relative humidity (controller) Up to 95% at 30 °C
- Atmospheric pressure Up to 10,000 feet

NONOPERATING

- Temperature -50 °C to +70 °C
- Relative humidity (controller) Up to 95% at 30 °C
- Atmospheric pressure Up to 40,000 feet
- Shock and vibration Normal handling by commercial carriers

TYPICAL REAR-PANEL VIEW



The material presented in this datasheet was current at the time of publication. L3 Narda-MITEQ's continuing product improvement program makes it necessary to reserve the right to change our mechanical and electrical specifications without notice. If either of these parameters is critical, please contact the factory to verify that the information is current.

This material consists of L3 Narda-MITEQ general capabilities information and does not contain controlled technical data as defined within the International Traffic in Arms (ITAR) Part 120.10 or Export Administration Regulations (EAR) Part 734.7-11.
D-379C/08.31.17

narda  **MITEQ**

435 Moreland Road

Hauppauge, NY 11788

Tel: 631-231-1700

Fax: 631-231-1711

Email: satcomsalesnm@L3T.com

www.nardamiteq.com