

# 12.5-30 Watt Hybrid

## Features

- Specifically designed for redundant or individual military or aerospace applications
- Completely self contained Thick Film Hybrid DC-DC Converter
- No external filter caps required
- Fully isolated design
- "Inhibit-not" function
- Power on soft start
- 300 kHz operation for low ripple and fast response time
- Built-in EMI input filter meets MIL-STD-461C requirements CE01, CE03, CS01, CS02 and CS06
- Short circuit and overvoltage protection
- Capability of external sync for switching frequencies
- Built-in test capability

## Specifications

**INPUT:** 28 VDC nominal  
 Range: 16 to 50 VDC continuous  
 18 to 50 VDC full power  
 Survives 80 V transients/MIL-STD-704A

**ISOLATION:**  
 Input to case: 500 VDC  
 Input to output: 500 VDC  
 Output to case: 100 VDC

**ENVIRONMENT:**  
 Storage temperature: -55°C to +150°C  
 Shock: 50 G's  
 Acceleration: 500 G's  
 Vibration: 30 G's

Grade M:  
 Full Power Output at  $T_{case} = +85^{\circ}C$   
 Linearly derates to zero at  $T_{case} = +115^{\circ}C$

Grade E:  
 Full Power Output at  $T_{case} = +125^{\circ}C$   
 Linearly derates to zero at  $T_{case} = +135^{\circ}C$

**WEIGHT:** 75 grams typical

## Note

Series 6680 is recommended over 2680 for new designs ("Inhibit not" function yields a higher level of noise immunity).

SINGLE OUTPUT DEVICES		6680-S02 (12W)			6680-S02.5 (15W)			6680-S03.3 (20W)			6680-S05 (30W)		
PARAMETER	CONDITION	MIN	TYP	MAX	MIN	TYP	MAX	MIN	TYP	MAX	MIN	TYP	MAX
Output voltage	—	+1.9	+2.0	+2.1	+2.4	+2.5	+2.6	+3.2	+3.3	+3.4	+4.9	+5.0	+5.1
Output current	$V_{in\ min} - V_{in\ max}$	—	—	6.06A	—	—	6.06A	—	—	6.06A	—	—	6A
Efficiency	$P_{out} = \text{max rated load}$	56%	59%	—	61%	64%	—	66%	69%	—	71%	74%	—
Line regulation	$P_{out} = \text{max rated load}$ $V_{in\ min} - V_{in\ max}$	—	10mV	30mV	—	10mV	30mV	—	10mV	30mV	—	10mV	50mV
Load regulation	$P_{out} = 10\%$ to F.L.	—	10mV	30mV	—	10mV	30mV	—	10mV	30mV	—	10mV	50mV
Output ripple	F.L. BW 2 MHz mV <sub>pp</sub>	—	25	50	—	30	60	—	30	65	—	40	85

SINGLE OUTPUT DEVICES		6680-S05.2 (30W)			6680-S12 (30W)			6680-S15 (30W)			6680-S28 (30W)		
PARAMETER	CONDITION	MIN	TYP	MAX	MIN	TYP	MAX	MIN	TYP	MAX	MIN	TYP	MAX
Output voltage	—	+5.1	+5.2	+5.3	+11.9	+12.0	+12.1	+14.9	+15.0	+15.1	+27.8	+28.0	+28.2
Output current	$V_{in\ min} - V_{in\ max}$	—	—	5.76A	—	—	2.5A	—	—	2A	—	—	1.07A
Efficiency	$P_{out} = \text{max rated load}$	71%	74%	—	78%	82%	—	79%	83%	—	78%	82%	—
Line regulation	$P_{out} = \text{max rated load}$ $V_{in\ min} - V_{in\ max}$	—	10mV	50mV	—	20mV	100mV	—	25mV	125mV	—	50mV	250mV
Load regulation	$P_{out} = 10\%$ to F.L.	—	10mV	50mV	—	20mV	100mV	—	25mV	125mV	—	50mV	250mV
Output ripple	F.L. BW 2 MHz mV <sub>pp</sub>	—	40	85	—	60	150	—	75	180	—	150	350

Model No.	Case Style	Pin Count	Mounting
6680	2	12	Solder Sealed Flangeless PCB Mount
6680	F	3	Solder Sealed PCB Mount with Flange
6680	I	5	Seam Weld Flangeless PCB Mount
6680	IF	6	Seam Weld PCB Mount with Flange
6680	WF	8	Seam Weld Chassis Mount with Flange
6680	PB	10	Solder Sealed Flangeless PCB Stud Mount
6680	PE	12	Seam Weld Flangeless PCB Stud Mount

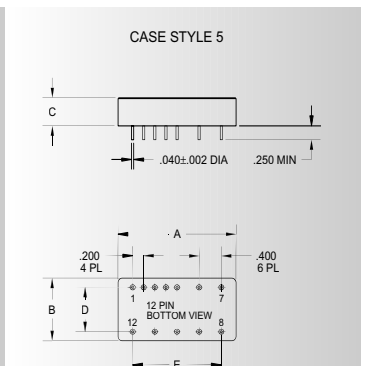
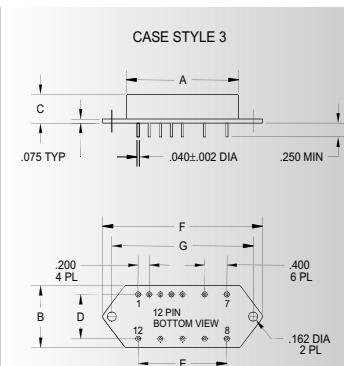
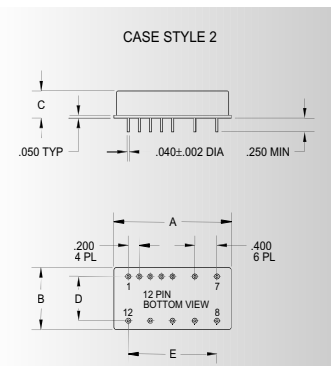

TOLERANCES: ALL DIMENSIONS ±0.01 EXCEPT F = MAX, C = +0.01/-0.02; DRAWINGS IN INCHES.

## Case Dimensions

Units: inches | millimeters

Case Style	A	B	C	D	E	F	G
2	2.200   55.880	1.350   34.290	0.495   12.573	1.000   25.400	1.600   40.640	—   —	—   —
3 F	2.200   55.880	1.350   34.290	0.495   12.573	1.000   25.400	1.600   40.640	2.960   75.184	2.610   66.294
5 I	2.225   56.515	1.350   34.290	0.495   12.573	1.000   25.400	1.600   40.640	—   —	—   —
6 IF	2.225   56.515	1.350   34.290	0.495   12.573	1.000   25.400	1.600   40.640	2.960   75.184	2.610   66.294
8 WF	2.225   56.515	1.710   43.434	0.495   12.573	—   —	1.600   40.640	2.960   75.184	2.610   66.294
10 PB	2.225   56.515	1.350   34.290	0.495   12.573	1.000   25.400	1.600   40.640	—   —	—   —
12 PE	2.225   56.515	1.350   34.290	0.495   12.573	1.000   25.400	1.600   40.640	—   —	—   —

# DC-DC CONVERTERS

## FULL FEATURE SERIES

# 6680

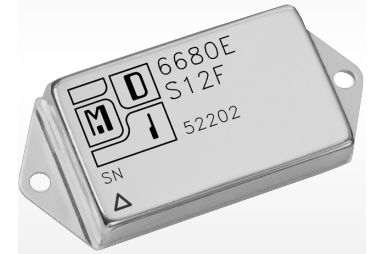

## 28 VDC

0006

DUAL OUTPUT DEVICES		6680-D3.3/5 (14.9W)			6680-D05 (30W)			6680-D12 (30W)			6680-D15 (30W)		
PARAMETER	CONDITION	MIN	TYP	MAX	MIN	TYP	MAX	MIN	TYP	MAX	MIN	TYP	MAX
Output voltage	$+I_{out} = -I_{out}$	+3.2	+3.3	+3.4	+4.9	+5.0	+5.1	+11.9	+12.0	+12.1	+14.9	+15.0	+15.1
		+4.9	+5.0	+5.1	-4.9	-5.0	-5.1	-11.9	-12.0	-12.1	-14.9	-15.0	-15.1
Output current*	$V_{in\ min} - V_{in\ max}$	300mA	—	3A	±150mA	—	±3A	±95mA	—	±1.25A	±76mA	—	±1A
		100mA	—	1A	—	—	—	—	—	—	—	—	—
Efficiency	$P_{out} = \text{max rated load}$	63%	66%	—	72%	76%	—	78%	82%	—	79%	83%	—
Line regulation	$P_{out} = \text{max rated load}$ $V_{in\ min} - V_{in\ max}$	—	±10mV	±30mV	—	±10mV	±50mV	—	±20mV	±100mV	—	±25mV	±125mV
		—	±10mV	±50mV	—	±10mV	±50mV	—	±20mV	±100mV	—	±25mV	±125mV
Load regulation†	$P_{out} = 10\%$ to F.L.	—	±10mV	±30mV	—	±10mV	±50mV	—	±20mV	±100mV	—	±25mV	±125mV
		—	±10mV	±50mV	—	±10mV	±50mV	—	±20mV	±100mV	—	±25mV	±125mV
Output ripple	F.L. BW 2 MHz mV <sub>pp</sub>	—	30	65	—	40	85	—	60	150	—	75	180
		—	25	50	—	—	—	—	—	—	—	—	—

Notes: \*Up to 90% full power available from either output if rated output power is not exceeded; †balanced load conditions.

TRIPLE OUTPUT DEVICES		6680-T3.3/5 (12.5W)			6680-T3.3/12 (17.5W)			6680-T3.3/15 (17.5W)			6680-T05 (12.5W)			6680-T12 (17.5W)			6680-T15 (17.5W)					
PARAMETER	CONDITION	MIN	TYP	MAX	MIN	TYP	MAX	MIN	TYP	MAX	MIN	TYP	MAX	MIN	TYP	MAX	MIN	TYP	MAX			
Output voltage	$+I_{out} = -I_{out}$	+3.2	+3.3	+3.4	+3.2	+3.3	+3.4	+3.2	+3.3	+3.4	+4.9	+5.0	+5.1	+4.9	+5.0	+5.1	+11.9	+12.0	+12.1	+14.9	+15.0	+15.1
		+4.9	+5.0	+5.1	+11.9	+12.0	+12.1	+14.9	+15.0	+15.1	-4.9	-5.0	-5.1	-11.9	-12.0	-12.1	-14.9	-15.0	-15.1	-14.9	-15.0	-15.1
Output current	$V_{in\ min} - V_{in\ max}$	300mA	—	3A	300mA	—	3A	300mA	—	3A	90mA	—	2A	90mA	—	2A	90mA	—	2A	90mA	—	2A
		±40mA	—	±250mA	±40mA	—	±312mA	±32mA	—	±250mA	±40mA	—	±250mA	±40mA	—	±312mA	±32mA	—	±250mA	±40mA	—	±250mA
Efficiency	$P_{out} = \text{max rated load}$	66%	69%	—	66%	69%	—	66%	69%	—	66%	69%	—	71%	74%	—	71%	74%	—	71%	74%	—
Line regulation	$P_{out} = \text{max rated load}$ $V_{in\ min} - V_{in\ max}$	—	10mV	50mV	—	10mV	50mV	—	10mV	50mV	—	10mV	50mV	—	10mV	50mV	—	10mV	50mV	—	10mV	50mV
		—	25mV	50mV	—	25mV	50mV	—	25mV	50mV	—	25mV	50mV	—	25mV	50mV	—	25mV	50mV	—	25mV	50mV
Load regulation	$P_{out} = 10\%$ to F.L.	—	10mV	50mV	—	10mV	50mV	—	10mV	50mV	—	10mV	50mV	—	10mV	50mV	—	10mV	50mV	—	10mV	50mV
		—	25mV	50mV	—	25mV	50mV	—	25mV	50mV	—	25mV	50mV	—	25mV	50mV	—	25mV	50mV	—	25mV	50mV
Output ripple	F.L. BW 2 MHz mV <sub>pp</sub>	—	30	65	—	30	65	—	30	65	—	40	85	—	40	85	—	40	85	—	40	85
		—	—	50	—	—	50	—	—	50	—	—	50	—	—	50	—	—	50	—	—	50

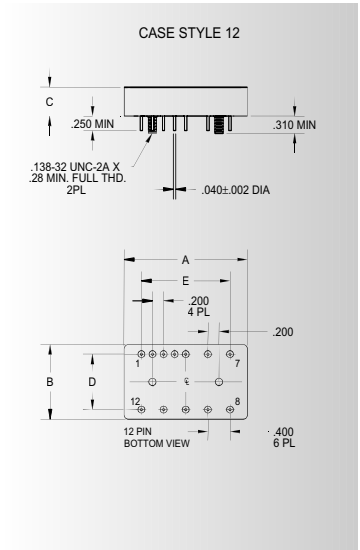
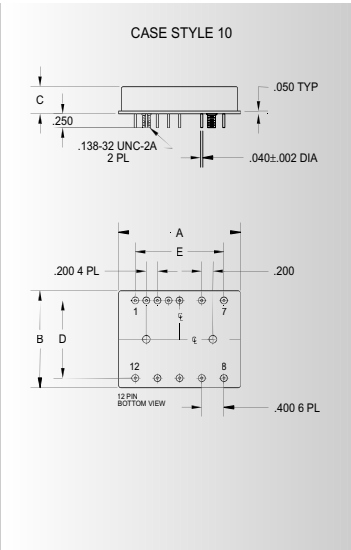
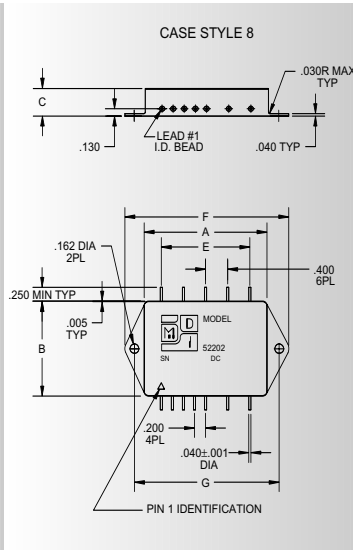
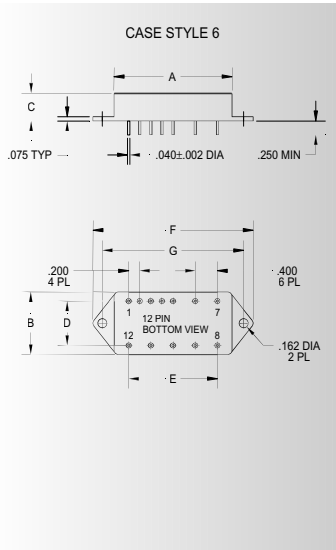

6680-SXX output <24 VDC				6680-SXX output ≥24 VDC				6680-DXX				6680-TXX			
Pin 1	bit	Pin 7	+ input	Pin 1	bit	Pin 7	+ input	Pin 1	bit	Pin 7	+ input	Pin 1	bit	Pin 7	+ input
Pin 2	inhibit not	Pin 8	main output	Pin 2	inhibit not	Pin 8	N/C	Pin 2	inhibit not	Pin 8	N/C	Pin 2	inhibit not	Pin 8	main output
Pin 3	soft start	Pin 9	main output ret	Pin 3	soft start	Pin 9	N/C	Pin 3	soft start	Pin 9	N/C	Pin 3	soft start	Pin 9	main output ret
Pin 4	sync	Pin 10	+ remote sense	Pin 4	sync	Pin 10	main output	Pin 4	sync	Pin 10	+ dual output	Pin 4	sync	Pin 10	+ dual output
Pin 5	N/C	Pin 11	adjust	Pin 5	N/C	Pin 11	N/C	Pin 5	N/C	Pin 11	dual output ret	Pin 5	N/C	Pin 11	dual output ret
Pin 6	input ret	Pin 12	- remote sense	Pin 6	input ret	Pin 12	main output ret	Pin 6	input ret	Pin 12	- dual output	Pin 6	input ret	Pin 12	- dual output

Please specify **GRADE LEVEL** for your application. Industrial grade units will be shipped if no option is specified.

- M** +85°C military
- E** +125°C military