

32.5-80 Watt Hybrid

Features

- Rad Hard: TID > 100kRad(Si)
- 2:1 margin: Operates beyond 200kRad TID
- No SEE: LET > 82MeV*cm²/mg
- Proton Resistant: No optocouplers used
- Specifically designed for redundant or individual space applications
- Completely self contained Thick Film Hybrid DC-DC Converter
- No external filter caps required
- Fully isolated design
- "Inhibit-not" function
- Power on soft start
- 200 kHz operation for low ripple and fast response time
- Built-in EMI input filter meets MIL-STD-461C requirements CE01, CE03, CS01, CS02 and CS06
- Short circuit and overvoltage protection
- Capability of external sync for switching frequencies
- Built-in test capability

Specifications

INPUT: 28 VDC nominal
 Range: 16 to 50 VDC continuous
 18 to 50 VDC full power

Survives 80 V transients/MIL-STD-704A

ISOLATION:

Input to case: 500 VDC
 Input to output: 500 VDC
 Output to case: 100 VDC

ENVIRONMENT:

Storage temperature: -55°C to +150°C
 Shock: 50 G's
 Acceleration: 500 G's
 Vibration: 30 G's

Grades EU, L, R & S:

Full Power Output at T_{case} = +85°C
 Linearly derates to zero at T_{case} = +115°C

Grades LE, RE & SE:

Full Power Output at T_{case} = +125°C
 Linearly derates to zero at T_{case} = +135°C

Grades L & LE:

TID up to 45kRad(Si)
 No SEE up to 60MeV*cm²/mg
WEIGHT: 160 grams typical

SINGLE OUTPUT DEVICES		5031-S02 (30W)			5031-S02.5 (37.5W)			5031-S03.3 (50W)			5031-S05 (75W)		
PARAMETER	CONDITION	MIN	TYP	MAX	MIN	TYP	MAX	MIN	TYP	MAX	MIN	TYP	MAX
Output voltage	—	+1.9	+2.0	+2.1	+2.4	+2.5	+2.6	+3.2	+3.3	+3.4	+4.9	+5.0	+5.1
Output current	V _{in min} — V _{in max}	—	—	15A	—	—	15A	—	—	15A	—	—	15A
Efficiency	P _{out} = max rated load	55%	58%	—	60%	63%	—	60%	73%	—	70%	73%	—
Line regulation	P _{out} = max rated load V _{in min} — V _{in max}	—	10mV	30mV	—	10mV	30mV	—	10mV	30mV	—	10mV	50mV
Load regulation	P _{out} = 10% to F.L.	—	10mV	30mV	—	10mV	30mV	—	10mV	30mV	—	10mV	50mV
Output ripple	F.L. BW 2 MHz mV _{pp}	—	25	50	—	30	60	—	30	65	—	40	85

SINGLE OUTPUT DEVICES		5031-S05.2 (78W)			5031-S12 (75W)			5031-S15 (75W)			5031-S28 (70W)		
PARAMETER	CONDITION	MIN	TYP	MAX	MIN	TYP	MAX	MIN	TYP	MAX	MIN	TYP	MAX
Output voltage	—	+5.1	+5.2	+5.3	+11.9	+12.0	+12.1	+14.9	+15.0	+15.1	+27.8	+28.0	+28.2
Output current	V _{in min} — V _{in max}	—	—	15A	—	—	6.25A	—	—	5A	—	—	2.5A
Efficiency	P _{out} = max rated load	70%	73%	—	77%	81%	—	78%	82%	—	77%	81%	—
Line regulation	P _{out} = max rated load V _{in min} — V _{in max}	—	10mV	50mV	—	20mV	100mV	—	25mV	125mV	—	50mV	250mV
Load regulation	P _{out} = 10% to F.L.	—	10mV	50mV	—	20mV	100mV	—	25mV	125mV	—	50mV	250mV
Output ripple	F.L. BW 2 MHz mV _{pp}	—	40	85	—	60	150	—	75	180	—	150	350

Model No.	Case Style	Pin Count	Mounting
5031	4	12	Solder Sealed PCB Mount with Flange
5031	LF	7	Seam Weld PCB Mount with Flange
5031	ZF	9	Seam Weld Chassis Mount with Flange
5031	PD	11	Solder Sealed Flangeless PCB Stud Mount

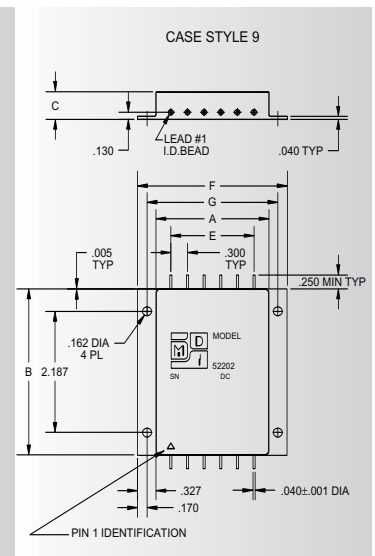
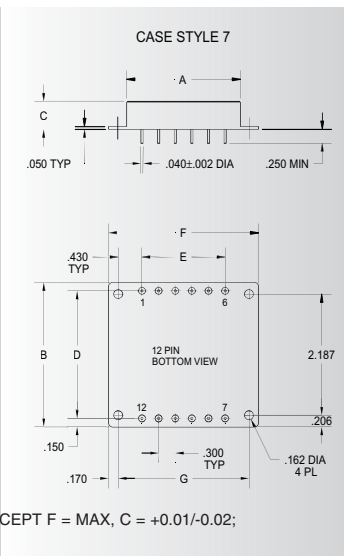
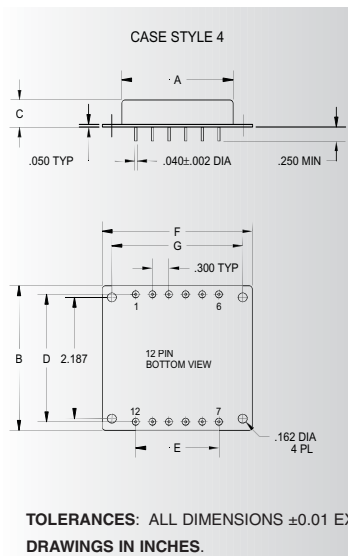

TOLERANCES: ALL DIMENSIONS ±0.01 EXCEPT F = MAX, C = +0.01/-0.02;
DRAWINGS IN INCHES.

Case Dimensions

Units: inches | millimeters

Case Style	A	B	C	D	E	F	G
4	2.040 51.816	2.610 66.294	0.495 12.573	2.300 58.420	1.500 38.100	2.710 68.834	2.360 59.944
7 LF	2.040 51.816	2.610 66.294	0.495 12.573	2.300 58.420	1.500 38.100	2.710 68.834	2.360 59.944
9 ZF	2.040 51.816	3.010 76.454	0.495 12.573	— —	1.500 38.100	2.710 68.834	2.360 59.944
11 PD	2.040 51.816	2.610 66.294	0.495 12.573	2.300 58.420	1.500 38.100	— —	— —

DC-DC CONVERTERS

PROTON RAD HARD 100K+™ SERIES

5031

MAGNETICALLY ISOLATED



28 VDC

DUAL OUTPUT DEVICES		5031-D3.3/5 (31.78W)			5031-D05 (75W)			5031-D12 (74.4W)			5031-D15 (75W)		
PARAMETER	CONDITION	MIN	TYP	MAX	MIN	TYP	MAX	MIN	TYP	MAX	MIN	TYP	MAX
Output voltage	$+I_{out} = -I_{out}$	+3.2	+3.3	+3.4	+4.9	+5.0	+5.1	+11.9	+12.0	+12.1	+14.9	+15.0	+15.1
		+4.9	+5.0	+5.1	+4.9	+5.0	+5.1	-11.9	-12.0	-12.1	-14.9	-15.0	-15.1
Output current*	$V_{in\ min} - V_{in\ max}$	660mA	—	6.6A	±266mA	—	±7.5A	±158mA	—	±3.1A	±127mA	—	±2.5A
		200mA	—	2A	—	—	—	—	—	—	—	—	—
Efficiency	$P_{out} = \text{max rated load}$	64%	67%	—	72%	75%	—	77%	81%	—	78%	82%	—
Line regulation	$P_{out} = \text{max rated load}$ $V_{in\ min} - V_{in\ max}$	—	10mV	30mV	—	±10mV	±50mV	—	±20mV	±100mV	—	±25mV	±125mV
		—	10mV	50mV	—	—	—	—	—	—	—	—	—
Load regulation†	$P_{out} = 10\%$ to F.L.	—	10mV	30mV	—	±10mV	±50mV	—	±20mV	±100mV	—	±25mV	±125mV
		—	10mV	50mV	—	—	—	—	—	—	—	—	—
Output ripple	F.L. BW 2 MHz mV _{pp}	—	30	65	—	40	85	—	60	150	—	75	180
		—	25	50	—	—	—	—	—	—	—	—	—

Notes: *Up to 90% full power available from either output if rated output power is not exceeded; †balanced load conditions.

TRIPLE OUTPUT DEVICES		5031-T3.3/5 (32.25W)			5031-T3.3/12 (42.75W)			5031-T3.3/15 (47.25W)			5031-T05 (32.5W)			5031-T12 (43W)			5031-T15 (47.5W)		
PARAMETER	CONDITION	MIN	TYP	MAX	MIN	TYP	MAX	MIN	TYP	MAX	MIN	TYP	MAX	MIN	TYP	MAX	MIN	TYP	MAX
Output voltage	$+I_{out} = -I_{out}$	+3.2	+3.3	+3.4	+3.2	+3.3	+3.4	+3.2	+3.3	+3.4	+4.9	+5.0	+5.1	+4.9	+5.0	+5.1	+4.9	+5.0	+5.1
		+4.9	+5.0	+5.1	+11.9	+12.0	+12.1	+14.9	+15.0	+15.1	+4.9	+5.0	+5.1	+11.9	+12.0	+12.1	+14.9	+15.0	+15.1
Output current	$V_{in\ min} - V_{in\ max}$	750mA	—	7.5A	750mA	—	7.5A	750mA	—	7.5A	90mA	—	5A	90mA	—	5A	90mA	—	5A
		±40mA	—	±750mA	±40mA	—	±750mA	±32mA	—	±750mA	±40mA	—	±750mA	±40mA	—	±750mA	±32mA	—	±750mA
Efficiency	$P_{out} = \text{max rated load}$	65%	68%	—	65%	68%	—	65%	68%	—	65%	68%	—	70%	73%	—	70%	73%	—
Line regulation	$P_{out} = \text{max rated load}$ $V_{in\ min} - V_{in\ max}$	—	10mV	50mV	—	10mV	50mV	—	10mV	50mV	—	10mV	50mV	—	10mV	50mV	—	10mV	50mV
		—	25mV	50mV	—	25mV	50mV	—	25mV	50mV	—	25mV	50mV	—	25mV	50mV	—	25mV	50mV
Load regulation	$P_{out} = 10\%$ to F.L.	—	10mV	50mV	—	10mV	50mV	—	10mV	50mV	—	10mV	50mV	—	10mV	50mV	—	10mV	50mV
		—	25mV	50mV	—	25mV	50mV	—	25mV	50mV	—	25mV	50mV	—	25mV	50mV	—	25mV	50mV
Output ripple	F.L. BW 2 MHz mV _{pp}	—	30	65	—	30	65	—	30	65	—	40	85	—	40	85	—	40	85
		—	—	50	—	—	50	—	—	50	—	—	50	—	—	50	—	—	50

CASE STYLE 11

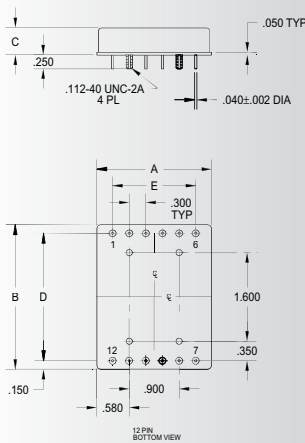

5031-SXX output <24 VDC

Pin 1	bit	Pin 7	N/C
Pin 2	inhibit not	Pin 8	main output
Pin 3	soft start	Pin 9	main output ret
Pin 4	sync	Pin 10	+ remote sense
Pin 5	+ input	Pin 11	adjust
Pin 6	input ret	Pin 12	- remote sense

5031-SXX output ≥24 VDC

Pin 1	bit	Pin 7	adjust
Pin 2	inhibit not	Pin 8	+ remote sense
Pin 3	soft start	Pin 9	- remote sense
Pin 4	sync	Pin 10	main output
Pin 5	+ input	Pin 11	N/C
Pin 6	input ret	Pin 12	main output ret

5031-DXX

Pin 1	bit	Pin 7	adjust
Pin 2	inhibit not	Pin 8	+ remote sense
Pin 3	soft start	Pin 9	- remote sense
Pin 4	sync	Pin 10	+ dual output
Pin 5	+ input	Pin 11	dual output ret
Pin 6	input ret	Pin 12	- dual output

5031-TXX

Pin 1	bit	Pin 7	N/C
Pin 2	inhibit not	Pin 8	main output
Pin 3	soft start	Pin 9	main output ret
Pin 4	sync	Pin 10	+ dual output
Pin 5	+ input	Pin 11	dual output ret
Pin 6	input ret	Pin 12	- dual output

Please specify **GRADE LEVEL** for your application. EU grade units will be shipped if no option is specified.

EU Engineering Units
R 100 K+™, +85°C military/aerospace
L 45 K, +85°C military/aerospace

RE 100 K+™, +125°C military/aerospace
S 100 K+™, +85°C space
LE 45 K, +125°C military/aerospace

SE 100 K+™, +125°C space