

# 4-10 WATT HYBRID

## POINT OF LOAD DC-DC REGULATORS

### NON-ISOLATED



### 12 VOLTS DC INPUT

#### Features

- Rad Hard: TID > 100kRad(Si)
- 2:1 margin: Operates beyond 200kRad TID
- No SEE:LET > 82MeV\*cm<sup>2</sup>/mg
- Proton Resistant: No optocouplers used
- Synchronous rectification for high efficiency
- Parallelable for higher current
- Non-isolated for intermediate bus applications
- Adjustable output voltage trim
- Thick Film Hybrid DC-DC Regulator
- "Inhibit-not" function
- 100kHz operation
- Sync input 1:1, 95-105 kHz
- Full hermetic package, solder seal and seam welded; PC and Chassis mount options

#### Specifications

**INPUT:** 12 VDC nominal

Range: 11 to 16 VDC continuous

**ISOLATION:**

Input-Output: Non-Isolated

Input and Output to case: 100 VDC

**OUTPUT:**

External capacitance recommended for specified performance

**ENVIRONMENT:**

Storage temperature: -55°C to +150°C

Shock: 50 G's

Acceleration: 500 G's

Vibration: 30 G's

Grades EU, R & S:

Full Output Power at T<sub>case</sub> = +85°C

Linearly derates to zero at

T<sub>case</sub> = +115°C

Grades RE & SE:

Full Power Output at T<sub>case</sub> = +125°C

Linearly derates to zero at

T<sub>case</sub> = +135°C

**WEIGHT:** 20 grams typical

### SERIES 5080

POSITIVE OUTPUT CONVERTERS		5080-P01 (4W)			5080-P01.2 (5W)			5080-P01.5 (6W)		
PARAMETER	CONDITION	MIN	TYP	MAX	MIN	TYP	MAX	MIN	TYP	MAX
Output voltage	(Trim Range)	+0.95	+1.0	+1.05	+1.15	+1.2	+1.25	+1.4	+1.5	+1.6
Output current	V <sub>in min</sub> — V <sub>in max</sub>	—	—	4A	—	—	4A	—	—	4A
Efficiency	P <sub>out</sub> = max rated load	—	73%	—	—	76%	—	—	78%	—
Line regulation	P <sub>out</sub> = max rated load V <sub>in min</sub> — V <sub>in max</sub>	—	10mV	30mV	—	10mV	30mV	—	10mV	30mV
Load regulation	P <sub>out</sub> = 10% to F.L.	—	10mV	30mV	—	10mV	30mV	—	10mV	30mV
Output ripple	F.L. BW 2 MHz mV <sub>pp</sub>	—	20	—	—	20	—	—	20	—
External Output Cap	(µF)	1000	—	4000	1000	—	4000	1000	—	4000
POSITIVE OUTPUT CONVERTERS		5080-P01.8 (7.2W)			5080-P02.0 (8W)			5080-P02.5 (10W)		
PARAMETER	CONDITION	MIN	TYP	MAX	MIN	TYP	MAX	MIN	TYP	MAX
Output voltage	(Trim Range)	+1.7	+1.8	+1.9	+1.9	+2.0	+2.1	+2.4	+2.5	+2.6
Output current	V <sub>in min</sub> — V <sub>in max</sub>	—	—	4A	—	—	4A	—	—	4A
Efficiency	P <sub>out</sub> = max rated load	—	79%	—	—	80%	—	—	81%	—
Line regulation	P <sub>out</sub> = max rated load V <sub>in min</sub> — V <sub>in max</sub>	—	10mV	50mV	—	10mV	50mV	—	20mV	100mV
Load regulation	P <sub>out</sub> = 10% to F.L.	—	10mV	50mV	—	10mV	50mV	—	20mV	100mV
Output ripple	F.L. BW 2 MHz mV <sub>pp</sub>	—	20	—	—	20	—	—	25	—
External Output Cap	(µF)	1000	—	4000	1000	—	4000	1000	—	4000
POSITIVE OUTPUT CONVERTERS		5080-P03.3 (10W)			5080-P05.0 (10W)			5080-P07.5 (10W)		
PARAMETER	CONDITION	MIN	TYP	MAX	MIN	TYP	MAX	MIN	TYP	MAX
Output voltage	(Trim Range)	+3.2	+3.3	+3.4	+4.9	+5.0	+5.1	+7.4	+7.5	+7.6
Output current	V <sub>in min</sub> — V <sub>in max</sub>	—	—	3A	—	—	2A	—	—	1.33A
Efficiency	P <sub>out</sub> = max rated load	—	87%	—	—	89%	—	—	89%	—
Line regulation	P <sub>out</sub> = max rated load V <sub>in min</sub> — V <sub>in max</sub>	—	25mV	125mV	—	50mV	250mV	—	65mV	300mV
Load regulation	P <sub>out</sub> = 10% to F.L.	—	25mV	125mV	—	50mV	250mV	—	65mV	300mV
Output ripple	F.L. BW 2 MHz mV <sub>pp</sub>	—	30	—	—	50	—	—	50	—
External Output Cap	(µF)	1000	—	4000	500	—	2000	500	—	2000
Model No.	Case Style	Pin Count		Mounting						
5080	1	18		Solder Sealed Flangeless PCB Mount						
5080 D	14	18		Seam Weld Flangeless PCB Mount						
5080 TF	15	18		Seam Weld Chassis Mount with Flange						



## PROTON RAD HARD 100K+<sup>®</sup> TECHNOLOGY

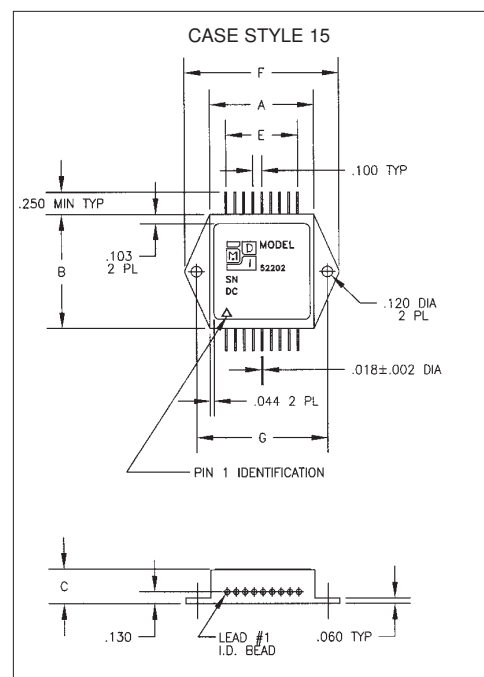
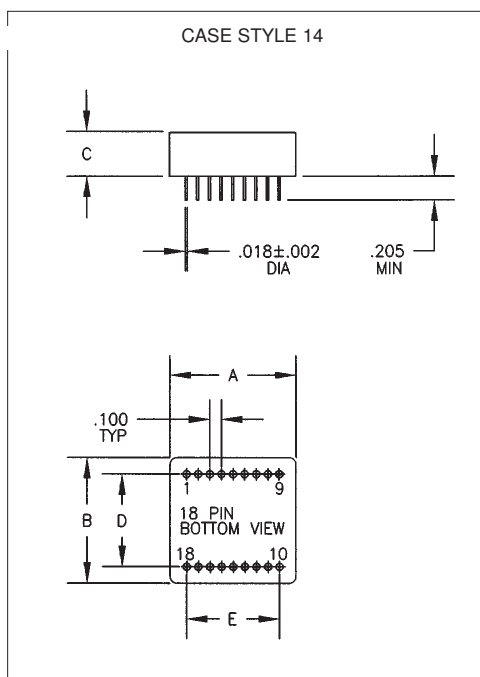
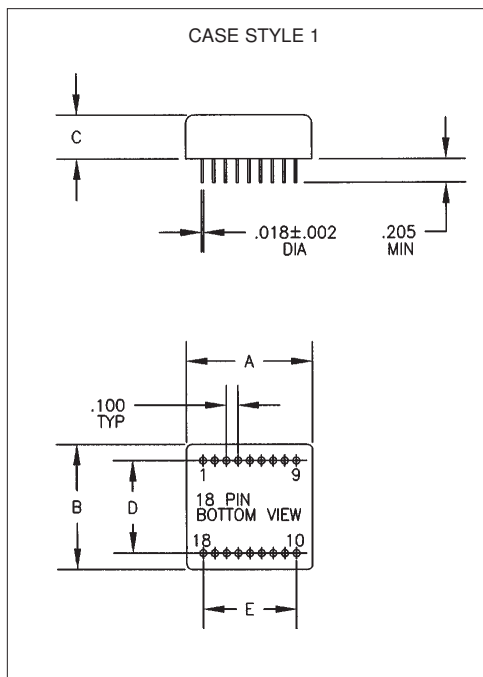

### Case Dimensions

Units: Inches | millimeters

TOLERANCES: Drawings in Inches All dimensions ±0.01 except F = max, C = +0.01/-0.020 For Custom Packages, Contact Factory

Case Style	A	B	C	D	E	F	G
1	1.080   27.432	1.080   27.432	0.380   9.625	0.800   20.320	0.800   20.320	—   —	—   —
14 D	1.090   27.686	1.090   27.686	0.380   9.625	0.800   20.320	0.800   20.320	—   —	—   —
15 TF	1.160   29.464	1.283   32.588	0.380   9.625	—   —	0.800   20.320	1.754   44.552	1.460   37.084

### Pin Outs

Pin 1 Positive Input	Pin 7 Output	Pin 13 Vref
Pin 2 Positive Input	Pin 8 Output	Pin 14 Adjust
Pin 3 Positive Input	Pin 9 Output	Pin 15 Iout
Pin 4 Common	Pin 10 Case	Pin 16 Sync
Pin 5 Common	Pin 11 Paralleling Input	Pin 17 Bit
Pin 6 Common	Pin 12 Paralleling Output	Pin 18 Inhibit Not

Specifications subject to change.

#### GRADE LEVELS:

Please specify **GRADE LEVEL** for your application. EU grade units will be shipped if no option is specified.

EU Engineering Units	S 100 K+™, +85°C space
R 100 K+™, +85°C military/aerospace	SE 100 K+™, +125°C space
RE 100 K+™, +125°C military/aerospace	

